

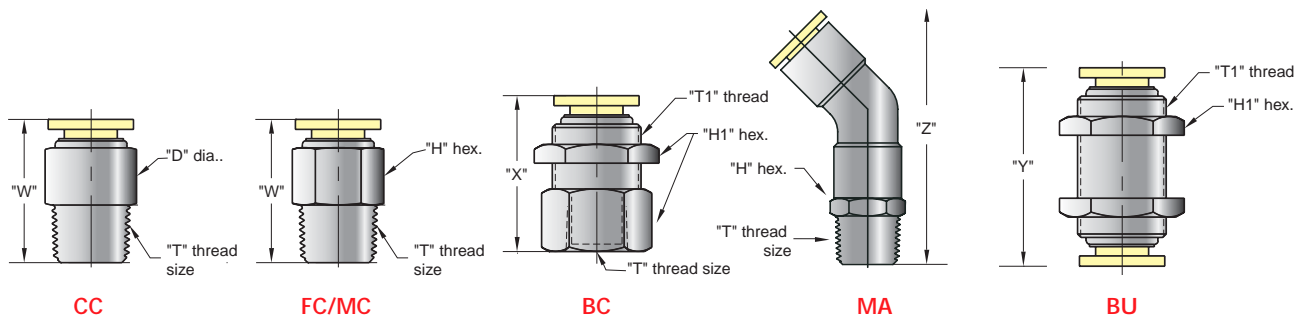

PUSH-QUICK FITTINGS

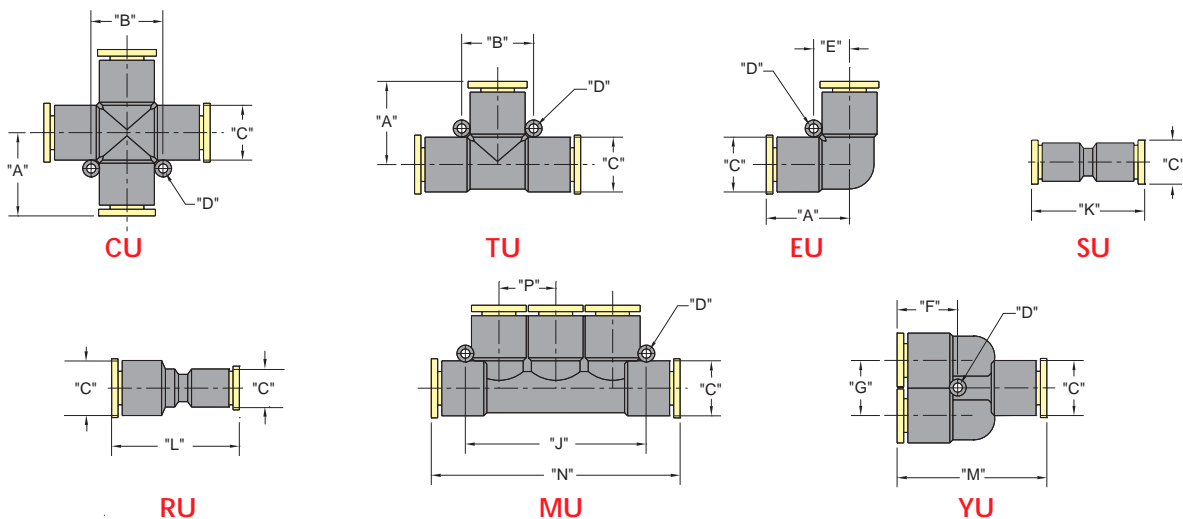

Tube Size	Thread Size "T"	"D"	"H"	"H1"	"T1"	"W"	"X"	"Y"	"Z"
1/8"	#10-32	0.410"			7/16"	0.880"			1.454
1/8"	1/8" NPT	0.410"			7/16"	0.860"			1.474
5/32" (4 mm)	#10-32	0.410"	7/16"		7/16"	0.890"	0.820"	0.440"	1.454"
5/32" (4 mm)	M5 x 0.8		10 mm		10 mm	0.900"	0.830"	0.450"	1.454
5/32" (4 mm)	1/8" NPT	0.410"	7/16"	5/8"	7/16"	0.840"	0.920"	0.570"	1.474
5/32" (4 mm)	R 1/8		10 mm	14 mm	10 mm	0.840"	0.920"	0.563"	1.474
5/32" (4 mm)	1/4" NPT		9/16"			0.920"			
6 mm	M5 X 0.8		12 mm		12 mm	0.950"	0.953"	0.500"	1.556
6 mm	R 1/8		10 mm	17 mm	12 mm	0.880"	0.976"	0.587"	1.556
6 mm	R 1/4		14 mm	17 mm	14 mm	0.875"	1.059"	0.654"	1.616
1/4"	#10-32	0.470"	1/2"		1/2"	0.913"	0.940"	0.480"	1.620
1/4"	1/8" NPT	0.470"	1/2"	3/4"	1/2"	0.913"	0.990"	0.600"	1.620
1/4"	1/4" NPT	0.530"	9/16"	3/4"	9/16"	0.965"	1.120"	0.740"	1.682
1/4"	3/8" NPT		11/16"		11/16"	0.965"			1.722
3/8"	1/8" NPT		11/16"		11/16"	1.280"			1.823
3/8"	1/4" NPT	0.670"	11/16"	15/16"	11/16"	1.342"	1.320"	0.800"	1.923
3/8"	3/8" NPT	0.670"	11/16"	15/16"	11/16"	1.241"	1.320"	0.900"	1.943
1/2"	1/4" NPT		7/8"		7/8"	1.380"			1.965
1/2"	3/8" NPT		7/8"		7/8"	1.320"			2.125
1/2"	1/2" NPT		7/8"		7/8"	1.320"			2.195



Tube Size	"A"	"B"	"C"	"D"	"E"	"F"	"G"	"J"	"K"	"L"	"M"	"N"	"P"
1/8"	0.710	0.560	0.420	0.080					1.240				
5/32" (4 mm)	0.722	0.656	0.410	0.125	0.328	0.512	0.517	1.608	1.239	1.230	1.318	2.312	0.531
6 mm	0.830	0.740	0.524	0.125	0.370	0.568	0.531	1.608	1.500	1.367	1.495	2.435	0.531
1/4"	0.840	0.740	0.524	0.125	0.370	0.604	0.531	1.608	1.500	1.666	1.495	2.435	0.531
3/8"	1.100	0.944	0.720	0.125	0.472	0.740	0.720	1.850	1.851	1.666	2.017	2.312	0.531
1/2"	1.130	1.120	0.850	0.100	0.570	0.780	0.840		1.810	1.810	2.070		